

TO-220 Plastic-Encapsulate Transistor's

TIP132 TRANSISTOR (NPN)

: 95HI F9G

- High DC Current Gain
- Electrically Similar to Popular TIP132
- Built-in a Damper Diode at E-C

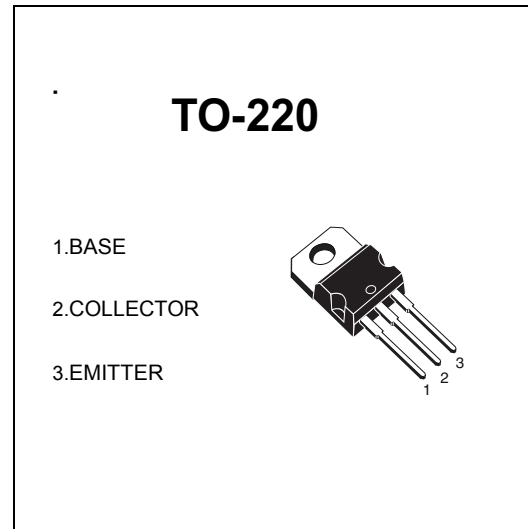

A5L-AI A F5HB; G (Ta=25°C unless otherwise noted)

Parameter	Description	Value	Unit
V_{CE}	Collector-Base Voltage	100	V
V_{CE}	Collector-Emitter Voltage	100	V
V_{BE}	Emitter-Base Voltage	5	V
I_C	Collector Current -Continuous	8	A
P_D	Collector Dissipation	2	W
$T_{j,STG}$	Junction and Storage Temperature	-55-150	°C

9 @ 7 HF 7 5 @ 7 < 5 F 5 7 H 9 F - G H 7 G (H18) °C i b`Ygg`ch Yfk jgY gdYWZQX

Parameter	Test Conditions	Value	Unit
$V_{(BR)CBO}$	$I_C=1mA, I_E=0$	100	V
$V_{(BR)CEO}$	$I_C=30mA, I_B=0$	100	V
$V_{(BR)EBO}$	$I_E=3mA, I_C=0$	5	V
I_{CBO}	$V_{CB}=100V, I_E=0$	10	μA
I_{CEO}	$V_{CE}=50V, I_E=0$	10	μA
I_{EBO}	$V_{EB}=5V, I_C=0$	2	mA
$h_{FE(2)}$	$V_{CE}=4V, I_C=4A$	1000	
	$V_{CE}=4V, I_C=8A$	100	
$V_{CE(sat)(1)}$	$I_C=4A, I_B=16mA$	2	V
	$I_C=8A, I_B=80mA$	4	V
$V_{BE(sat)}$	$I_C=8A, I_B=80mA$	4.5	V
V_{BE}	$V_{CE}=4V, I_C=4A$	2.8	V
C_{ob}	$V_{CB}=10V, I_E=0, f=0.1MHz$	200	pF