

## TO-126 Plastic-Encapsulate Transistors

### D882 TRANSISTOR (NPN)

#### FEATURES

- Power Dissipation

#### MAXIMUM RATINGS (T<sub>a</sub>=25°C unless otherwise noted)

Symbol	Parameter	Value	Unit
V <sub>CB0</sub>	Collector-Base Voltage	40	V
V <sub>CEO</sub>	Collector-Emitter Voltage	30	V
V <sub>EBO</sub>	Emitter-Base Voltage	6	V
I <sub>C</sub>	Collector Current -Continuous	3	A
P <sub>C</sub>	Collector Power Dissipation	1.25	W
T <sub>J</sub>	Junction Temperature	150	°C
T <sub>stg</sub>	Storage Temperature	-55-150	°C

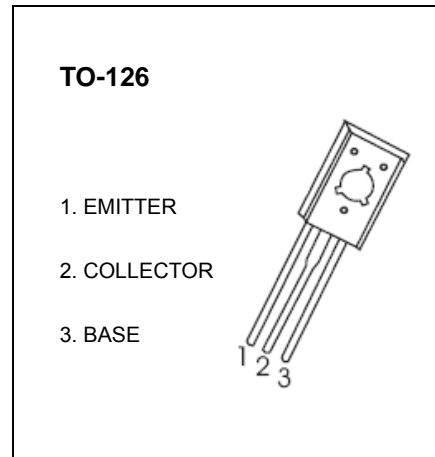

#### ELECTRICAL CHARACTERISTICS ( T<sub>a</sub>=25 °C unless otherwise specified)

Parameter	Symbol	Test conditions	Min	Typ	Max	Unit
Collector-base breakdown voltage	V(BR) <sub>CB0</sub>	I <sub>C</sub> = 100μA, I <sub>E</sub> =0	40			V
Collector-emitter breakdown voltage	V(BR) <sub>CEO</sub>	I <sub>C</sub> = 10mA, I <sub>B</sub> =0	30			V
Emitter-base breakdown voltage	V(BR) <sub>EBO</sub>	I <sub>E</sub> = 100μA, I <sub>C</sub> =0	6			V
Collector cut-off current	I <sub>CB0</sub>	V <sub>CB</sub> = 40 V, I <sub>E</sub> =0			1	μA
Collector cut-off current	I <sub>CEO</sub>	V <sub>CE</sub> = 30 V, I <sub>B</sub> =0			10	μA
Emitter cut-off current	I <sub>EBO</sub>	V <sub>EB</sub> = 6 V, I <sub>C</sub> =0			1	μA
DC current gain	h <sub>FE</sub>	V <sub>CE</sub> = 2 V, I <sub>C</sub> = 1A	60		400	
Collector-emitter saturation voltage	V <sub>CE(sat)</sub>	I <sub>C</sub> = 2A, I <sub>B</sub> = 0.2 A			0.5	V
Base-emitter saturation voltage	V <sub>BE(sat)</sub>	I <sub>C</sub> = 2A, I <sub>B</sub> = 0.2 A			1.5	V
Transition frequency	f <sub>T</sub>	V <sub>CE</sub> = 5V, I <sub>C</sub> =0.1A f =10MHz		90		MHz

#### CLASSIFICATION OF h<sub>FE</sub>

Rank	R	O	Y	GR
Range	60-120	100-200	160-320	200-400